

SEIT 1928

KONDENSATORMIKROFONE
FÜR STUDIO - UND MESSTECHNIK

MICROTECH GEFELL



UM 900

VALVE CONDENSER MICROPHONE

with
phantom powering

48 V

Large diameter dual membrane capsule, switchable

○ ○ ∞ ∞ 8

Balanced output transformer

Level reduction pad 10 dB

Level increase gain 4 dB

Bass roll-off switch

Satin nickel finish

Dark bronze finish

MICROPHONE

The UM 900 is the first switchable pattern, valve condenser microphone which can be connected to industry standard 48 volt phantom powering using a normal 3-pin XLR microphone cable. This is made possible by an advanced circuit design for the amplifier and internal power supply. The pickup capsule uses a traditional, proven design with two large, gold plated plastic membranes.

Three switches are located around the body of the UM 900. The switch in the front selects the polar pattern: omni, wide cardioid, cardioid, hyper cardioid and figure 8. Located 120 degrees to each side are switches for gain adjust and low frequency roll-off.

The unusual shape of the microphone's body is especially designed to minimize undesirable reflections of sound toward the pickup element.

Acoustic influences which could result from the housing resonance and/or mechanical vibration are reduced by the robust construction and by a special fixture within the microphone's housing which dampens vibration.



The UM 900 shown with its integrated elastic suspension can be swiveled 135 degrees to both sides.

FIXTURE

UM 900 shown with optional elastic suspension EA 92



UM 900 shown with optional swivel mount MH 80.



APPLICATION

The high sensitivity and low noise of the UM 900 make it especially suitable for vocal and speech pickup in professional sound recording studios, scoring stages and broadcast studios. The 5 pickup patterns allow the microphone to be tailored to a wide variety of applications. For example, the microphone can be used as an overall pickup for a large orchestra or it can be used as a solo or spot mike for individual instruments. It may also serve as an announce microphone where its proximity effect may be desirable.

ACOUSTICAL FEATURES

The direction of maximum sensitivity is radial to the microphone body, i.e. side addressed. The front of the microphone is indicated by the model number and the pattern selector switch.

The pick-up capsule is mounted in a large, acoustically open headgrill which prevents mechanical vibration interference. This gives the microphone a clean, colorless sound characteristic.

ELECTRICAL FEATURES

The internal vacuum tube amplifier of the UM 900 can be powered by any external 48 volt phantom supply which can provide at least 4 mA of current.

The amplifier uses a specially selected vacuum tube.

An internal transverter provides all the necessary voltages.

The low impedance output is implemented with an operational amplifier and balanced output transformer.

The UM 900 can be connected with a cable of up to 150 m length without any effect on sound quality.

SWITCHING FUNCTIONS



All switches can be turned continuously left or right without stops.

POLAR PATTERNS

The microphone features 5 pickup patterns: omni, wide cardioid, cardioid, hyper cardioid, figure 8.



LEVEL ADJUSTMENT

3 positions are selectable.

NOTE: When the "+4" position is selected, the pattern switch on the front of the microphone is disabled. Only the cardioid pattern functions at the higher sensitivity of +4dB.



REDUCED BASS ROLL-OFF

2 positions are selectable.

The sensitivity at 70 Hz is reduced by 10 dB in the position 

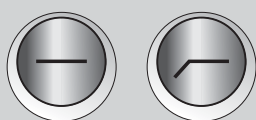

DELIVERY Microphone in a wooden case LxWxH 250x175x110 mm

Ordering example:



ACCESSORIES, optional

Windscreen	W 81	Order-No. 202407
... for mounting with EA 92 / MH 80	W 82	Order-No. 202409
Popscreen	PO 70	Order-No. 600018
Elastic suspension, satin nickel	EA 92	Order-No. 202312
Elastic suspension, dark bronze	EA 92	Order-No. 202313
Microphone holder, satin nickel	MH 80	Order-No. 202320
Microphone holder, dark bronze	MH 80	Order-No. 202322
Power supply	N 200	Order-No. 202101
Connection cable	C 70	Order-No. 202212

FREQUENCY RESPONSES

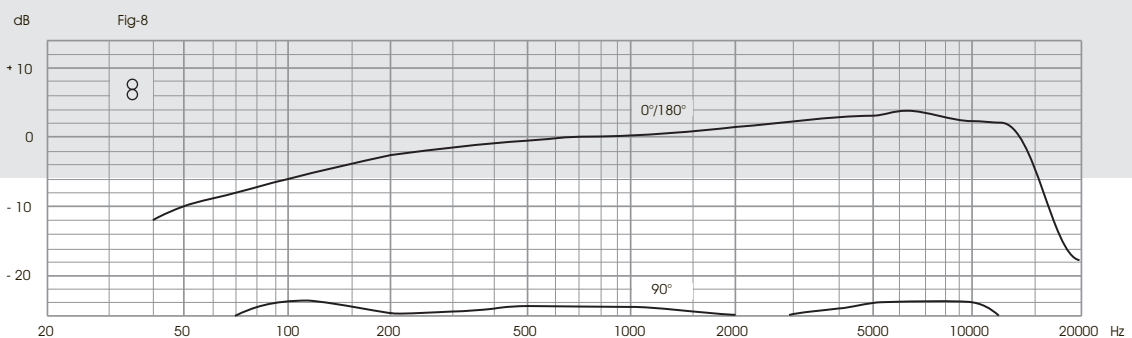
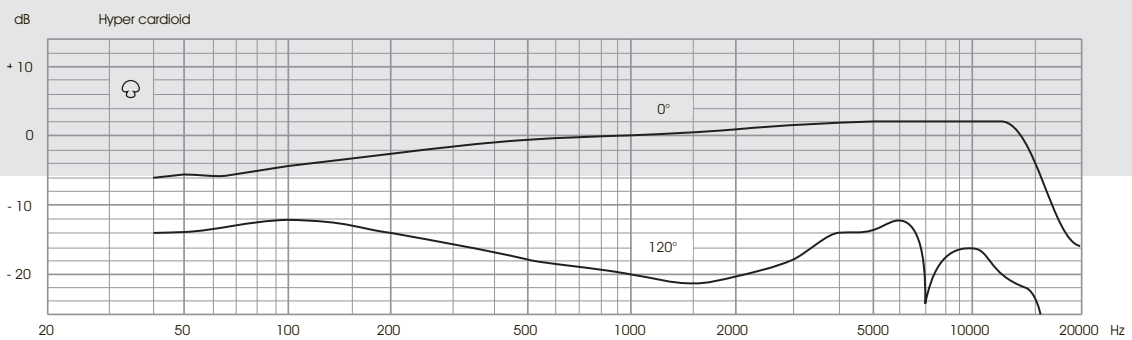
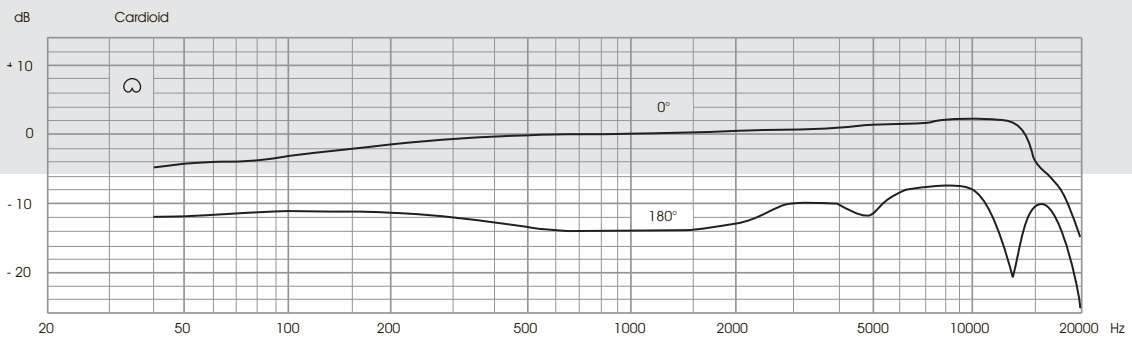
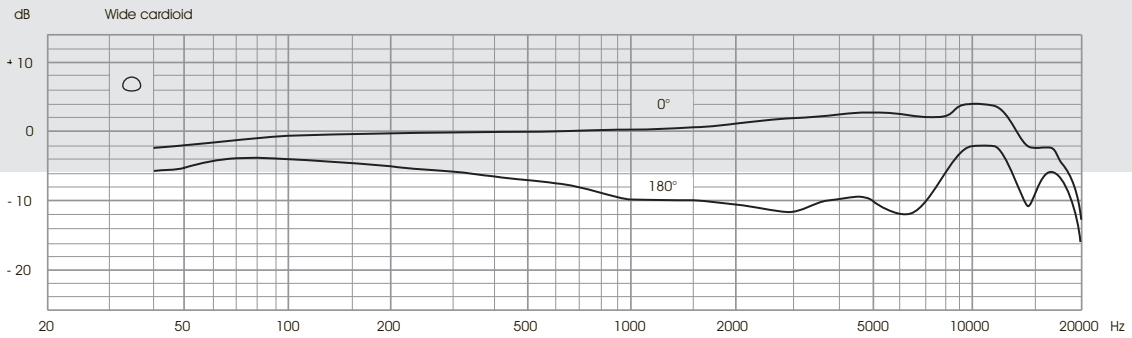
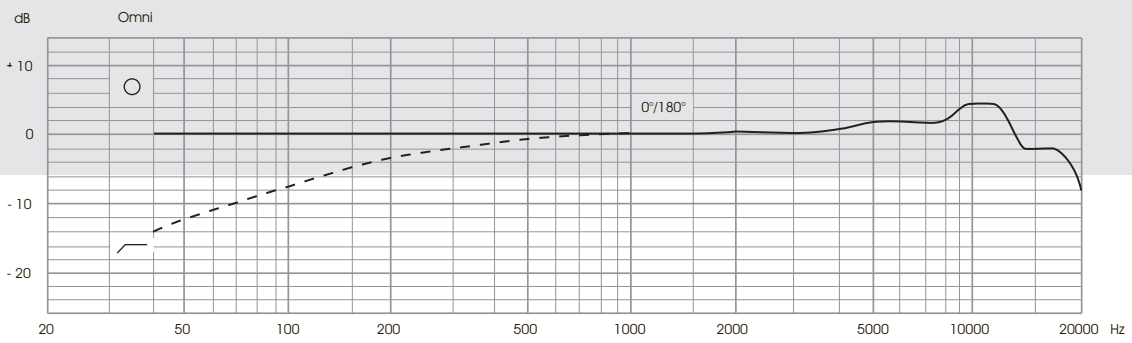

POLAR PATTERNS UM 900

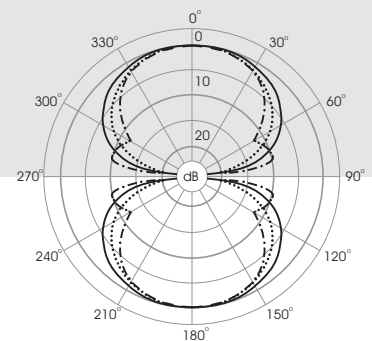
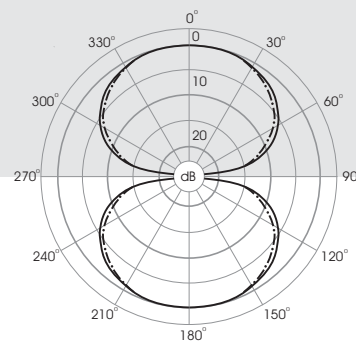
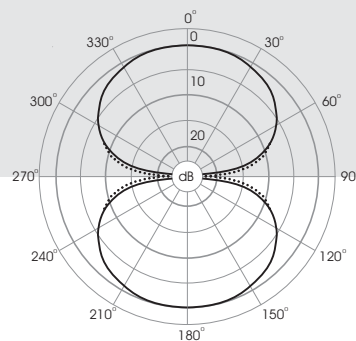
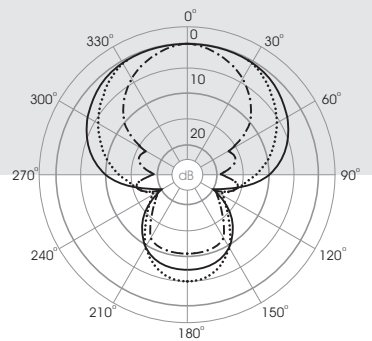
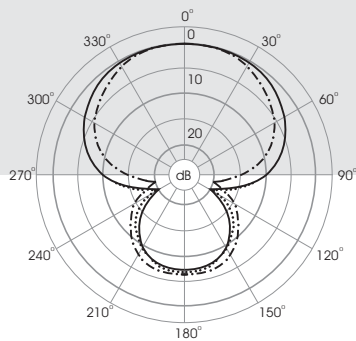
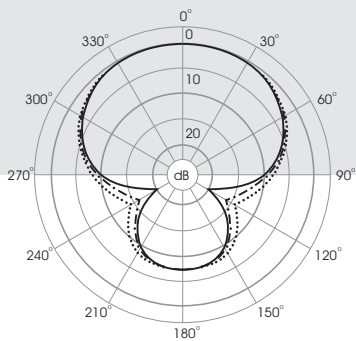
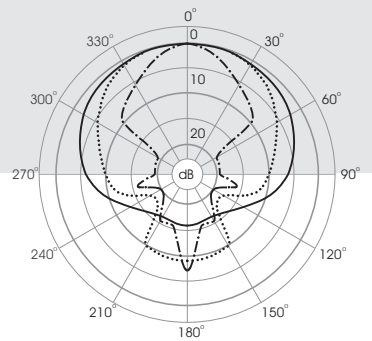
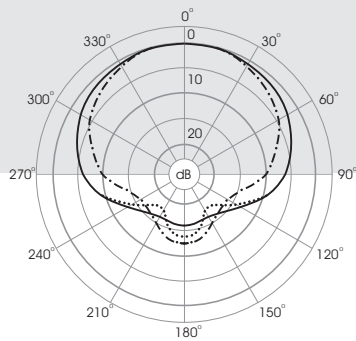
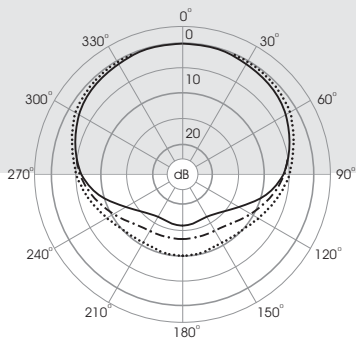
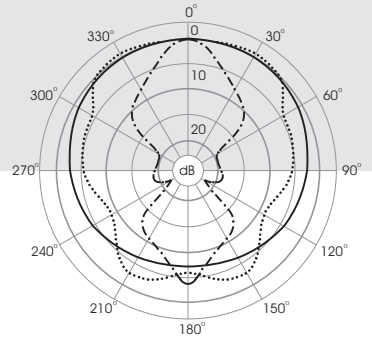
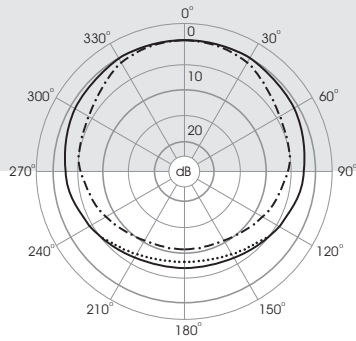
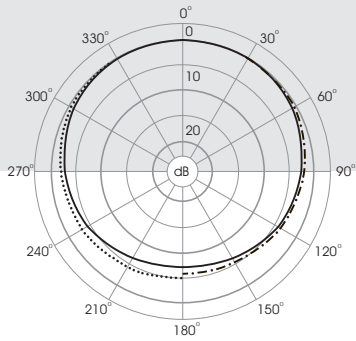
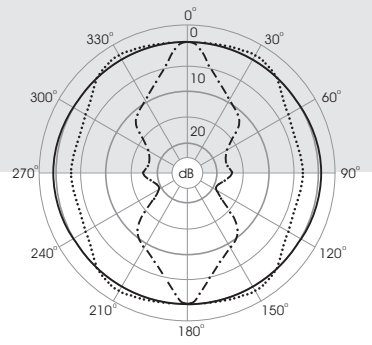
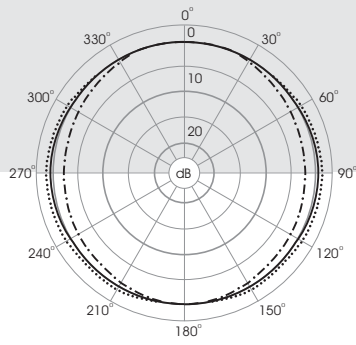
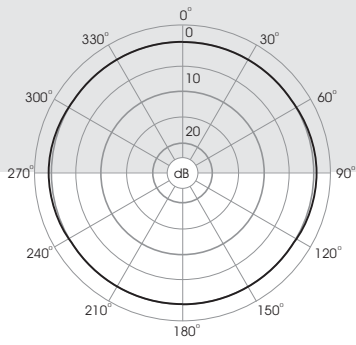

— 1 kHz
 250 Hz
 - - - 500 Hz

— 1 kHz
 2 kHz
 - - - 4 kHz

— 1 kHz
 8 kHz
 - - - 16 kHz

TECHNICAL SPECIFICATIONS

Valve - condenser microphone with switchable polar pattern

Polar patterns omni, wide cardioid, cardioid, hypercardioid, fig-8

Acoustical operating principle Pressure gradient transducer

Large diameter membrane capsule dual membran

Frequency range 40 . . . 18000 Hz

Sensitivity at 1 kHz 25/ cardioid 40 mV/Pa

Level selector switch - 10/ cardioid +4 dB

Switch position "reduced bass roll-off" at 70 Hz - 10 dB

Rated impedance 30 Ω

Equivalent loudness level CCIR 468 - 4 26 dB
due to inherent noise IEC 651 16 dB - A

Signal - to - noise ratio CCIR - weighted 68 dB
(re 1 Pa at 1 kHz) A - weighted 78 dB

Max. SPL for THD $\leq 0,5\%$ 130 dB
with 10 dB preattenuation 140 dB

Total dynamic range 114 dB

Current consumption (48 V phantom powering) 4 mA

Sub - miniature valve low noise version

Output connector 3 - pin XLR connector, goldplated contacts

Weight 900 g

Dimensions (L x \varnothing) 200 mm x 75 mm

Finish satin nickel, dark bronze

CE Certificate